

Specifications

MODELS		GS™-2046	
MEASUREMENTS		Metric	US
	Working height maximum	8.10 m	26 ft
A	Platform height maximum	6.10 m	20 ft
B	Platform height stowed	1.04 m	3 ft 4.8 in
C	Platform length - outside	2.26 m	7 ft 5 in
	- extended	3.18 m	10 ft 5 in
	Slide-out platform extension deck	0.91 m	3 ft
D	Platform width - outside	1.15 m	3 ft 9.3 in
	Guardrail height	1.09 m	3 ft 7 in
	Toeboard height	0.15 m	6 in
E	Height- stowed : folding guardrails	2.13 m	7 ft
	: rails folded	1.55 m	5 ft 1 in
F	Length- stowed	2.41 m	7 ft 11 in
	- extended	3.31 m	10 ft 10.5 in
G	Width	1.17 m	3 ft 10 in
H	Wheelbase	1.85 m	6 ft 1 in
I	Groundclearance - centre	0.10 m	4 in
J	- with pothole guards deployed	0.02 m	0.75 in
PRODUCTIVITY			
	Maximum platform capacity - indoor	2	2
	- outdoor	2	2
	Lift capacity	544 kg	1,200 lbs
	Lift capacity - extension deck	113 kg	250 lbs
	Drive speed - stowed	3.5 km/h	2.2 mph
	Drive speed - raised	0.8 km/h	0.5 mph
	Gradeability	30%	30%
	Turning radius - inside	zero	zero
	Turning radius - outside	2.29 m	7 ft 6 in
	Raise/ lower speed	30 / 33 sec	30 / 33 sec
	Controls	proportional	
	Drive	dual front wheel	
	Multiple disc brakes	dual rear wheel	
	Tyres - solid non-marking	38 x 13 x 28 cm	15 x 5 x 11 in
POWER			
	Powersource	24 V DC (four 6 V 225 Ah batteries)	
	Hydraulic system capacity	14.2 L	3.75 gal
WEIGHT			
		1,974 kg	4,351 lbs

STANDARDS COMPLIANCE ANSI A92.6, CSA B354.2, CE Compliance, AS 1418.10

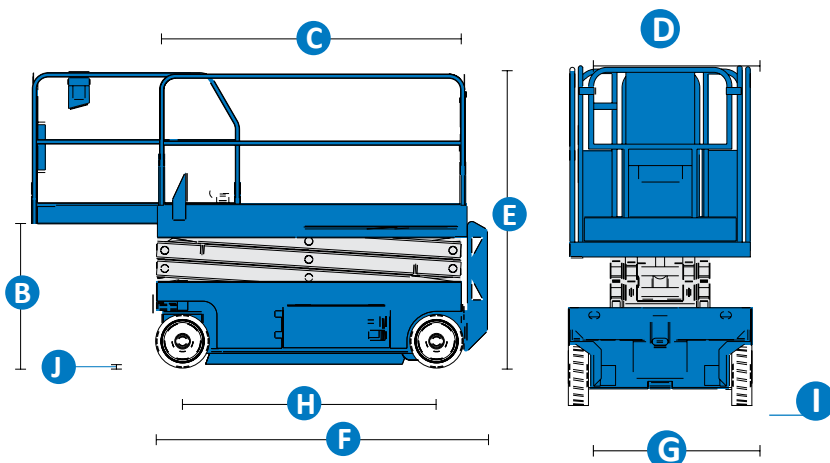

STANDARD FEATURES

- Folding rails with full height swing gate
 - Dual front wheel drive
 - Proportional lift and drive
 - Platform control with battery charge indicator and diagnostic display
 - Onboard diagnostic system
 - Lanyard attachment points
 - Manual platform lowering valve
 - Emergency stop at both platform and ground controls
 - Rear wheel multiple disc brakes
 - Front wheel hydraulic dynamic braking
 - Brake release
 - Drive speed interlock
 - Swing-out component tray
 - Solid non-marking tyres
 - Pothole guards
 - Tilt alarm
 - Descent alarm
 - Electronic horn
 - Hour meter
 - Dual flashing beacons
 - Motion alarm
- POWER**
- 24 V DC (four 6 V 225 Ah batteries)
 - Universal 20 amp smart charger

